

S-AWC

Super All Wheel Control



S-AWC systematic

What S-AWC aims to achieve

To reflect driver intent when accelerating, decelerating or cornering under all driving conditions using integrated management of brake force and drive torque at each of the four wheels.

Features (Steps beyond the Lancer Evolution IX MR)

1. Addition of ASC (Active Stability Control) to ACD, AYC and ABS components and integrated management of all four systems.
2. Addition of yaw rate feedback control.
3. Addition of brake force control to AYC system.

S-AWC systematic

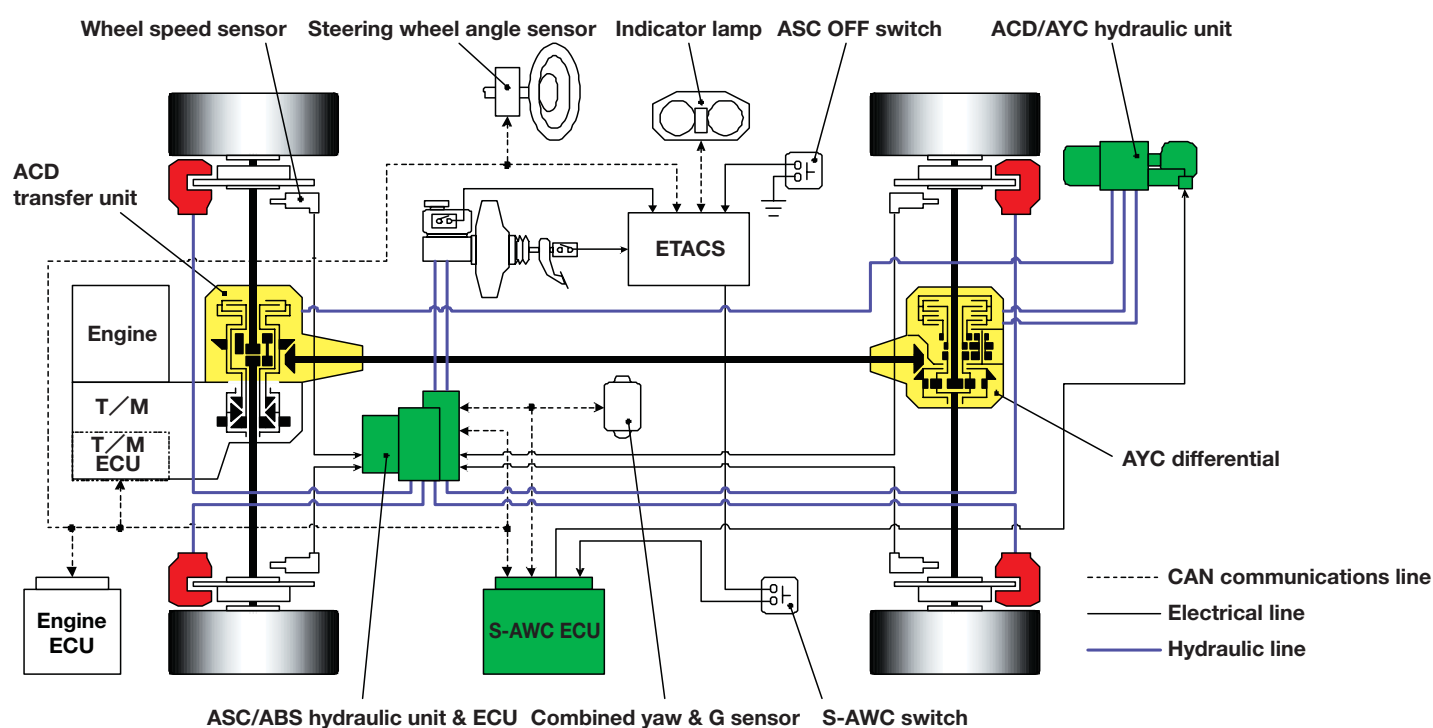

S-AWC benefits

Sport driving on high-friction surfaces

Lap time (1 lap of 2.4 km handling circuit)

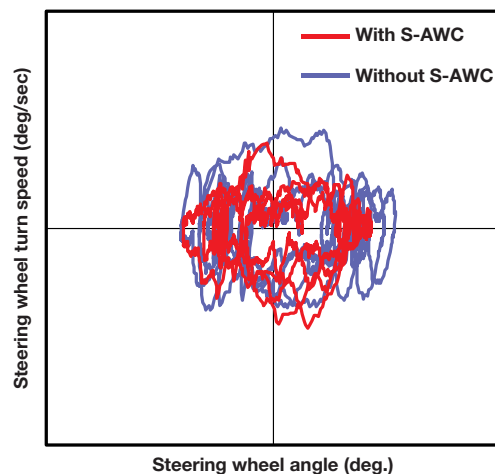
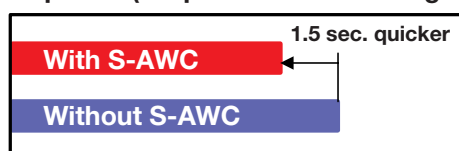

Steering response is improved
(can drive faster without having to turn steering wheel quicker)

Cornering on low-friction surface

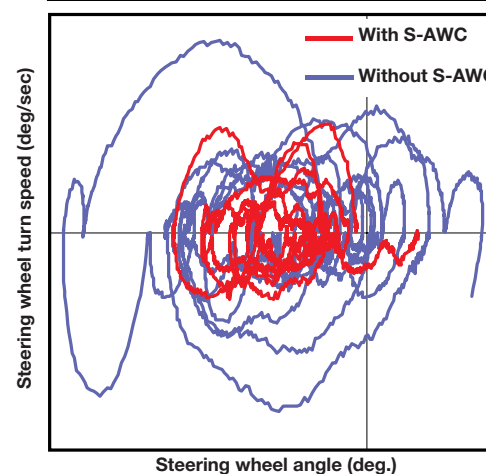
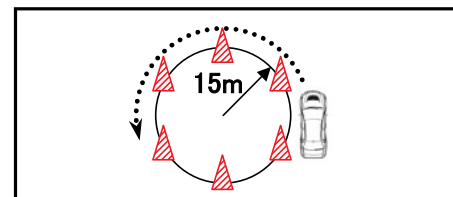

Stability and control are improved
(car turns with fewer steering corrections)

This realizes the objectives of "handling that faithfully follows driver inputs" and "rock-steady stability"